

INSTRUCTION MANUAL
PLEASE RETAIN

DO NOT USE APPLIANCE WITHOUT
READING THIS FIRST



THIS MANUAL COVERS

- RWLMSP20

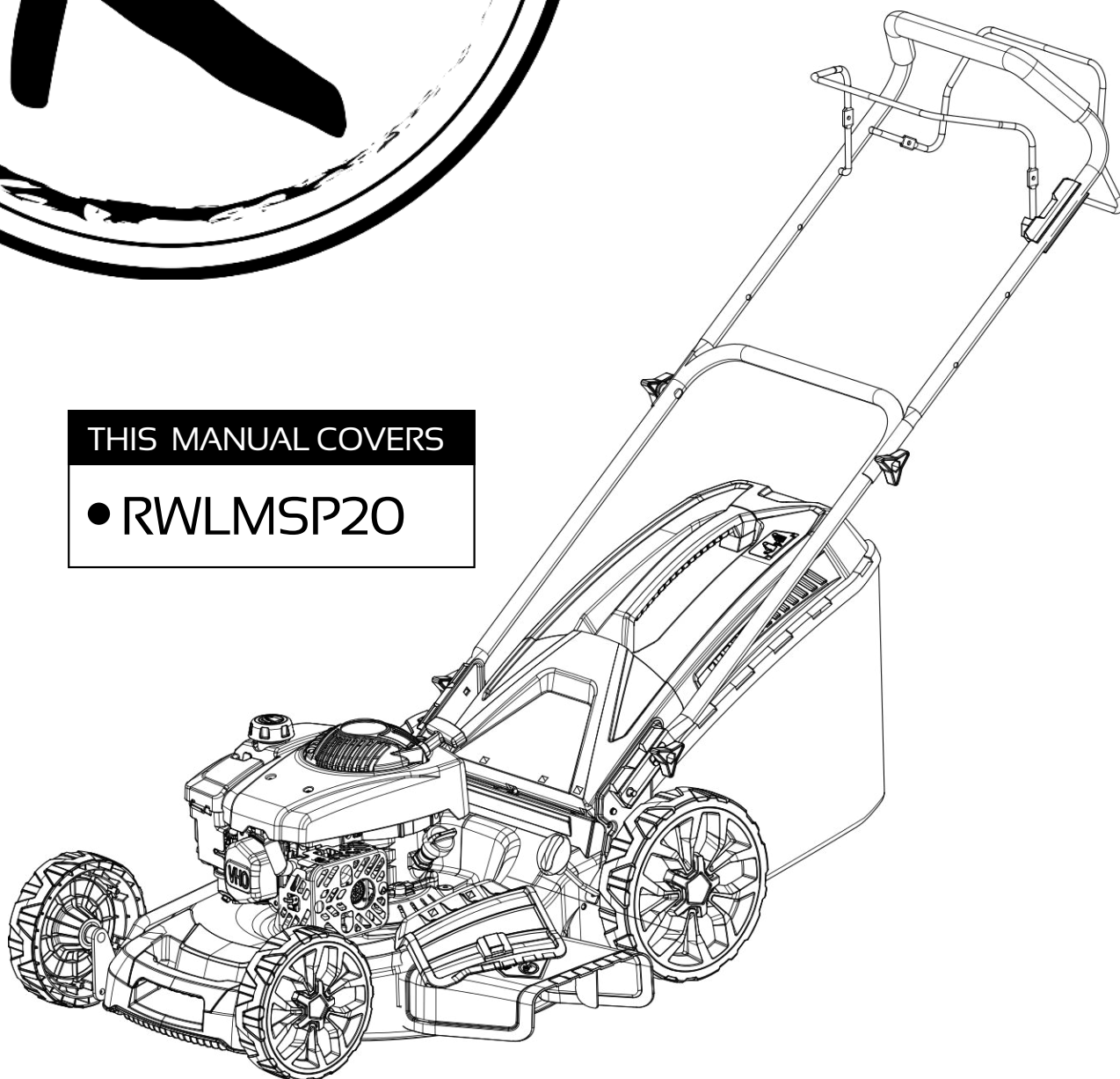

PETROL LAWN MOWER

TABLE OF CONTENTS

Description of Product Parts	3
Technical Specifications.....	4
Intended use.....	4
Safety Information.....	5
Assembly	9
Adjustment	13
Operation	14
Storing and Maintenance	17
Troubleshooting.....	21

DESCRIPTION OF PRODUCT PARTS

As shown in Fig 1

1. Drive lever (clutch lever)
2. soft grip
3. Upper handle
4. Brake lever /stop lever
5. Fixing knob with square neck blot
6. Lower handle
7. Grass box
8. Fuel tank cap
9. Primer
10. Front decorative cover
11. Height adjusting handle
12. Rear wheel
13. Engine oil cap
14. Side discharge cover
15. Side discharge chute
16. Deck
17. Spark plug boot
18. Starter handle
19. Rear discharge cover
20. Front wheel

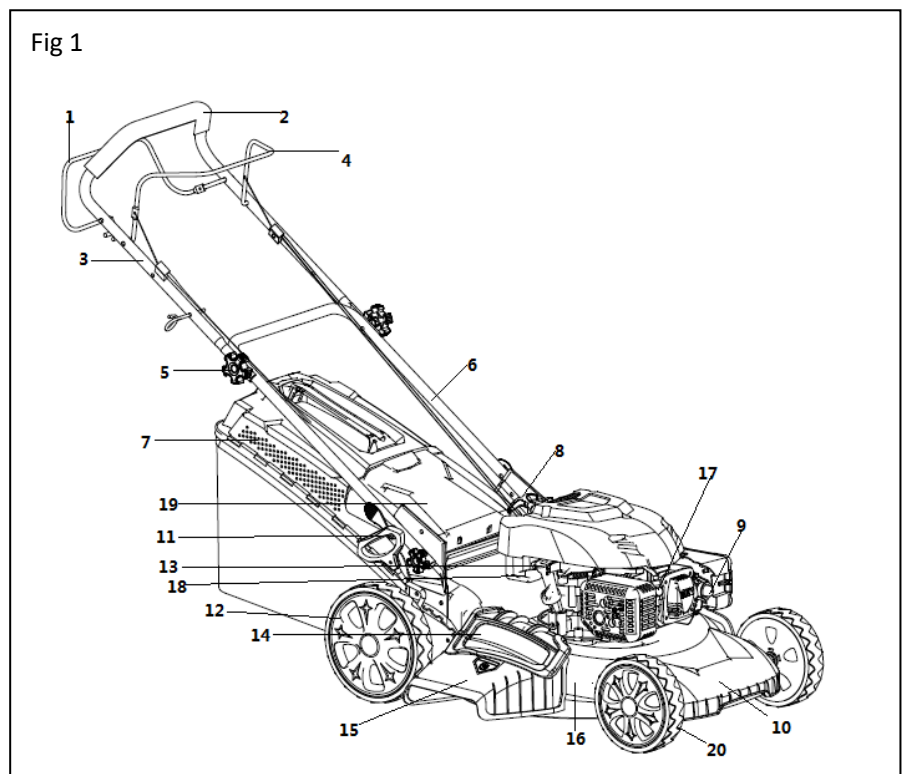

TECHNICAL SPECIFICATIONS

Model	RWLMSP20
Drive type	Self-propelled
Engine type	DV170
Engine displacement	173CC
Engine max. power	3.0KW
Engine speed	2800 rpm
Cutting width	510MM
Cutting height	25-75MM
Front/Rear wheel:	8/10inch
Grass bag capacity	60L
Sound power level (LWA)*	98 dB(A)

INTENDED USE

This Petrol lawn mower has been designed for cutting lawn areas in private house and hobby gardens.

The machine is to be used only for its prescribed purpose. any other use is Deemed to be a case of misuse. The user/operator and not the manufacturer will be liable for any damage or injuries of any kind caused as a result of this.

Please note that our equipment has not been designed for use in commercial, trade or industrial applications. our warranty will be voided if the machine is used in commercial, trade or industrial businesses or for equivalent purposes.

SAFETY INFORMATION

IMPORTANT

Please read these instructions fully before assembling and operating.

Description Of Symbols

Symbols are used in this manual to attract your attention to possible risks. The safety symbols and the explications which accompany them must be perfectly understood. The warning themselves do not prevent the risks and cannot be a substitute for proper methods of avoiding accidents.

Warning symbols on the machine



WARNING- To reduce the risk of injury, user must read instruction manual.



This symbol, before a safety comment, indicates a precaution, a warning or a danger. Ignoring this warning can lead to an accident for yourself or for others. To limit the risk of injury, fire, or electrocution always apply the recommendations indicated.



Keep bystanders away.



Beware of sharp blades –remove spark plug lead before maintenance.



Never refuel while the engine is running.



Risk of injury. Do not open or remove safety shields while engine is running.



Wear ear protection & eye protection when operating.



Hot surfaces can cause burns.



Warning! The lawnmower exhaust gas contains toxic substances. Do not run the engine in closed or poorly ventilated areas.



Conforms to relevant safety standards.



Waste electrical products should not be disposed of with household waste. Please recycle where facilities exist. Check your local authority or retailer for recycling advice.

Safety instructions.

Training

1. Read the instructions carefully. Be familiar with the controls and the proper use of the equipment.
2. Never allow children or people unfamiliar with these instructions to use the lawnmower. Local regulations can restrict the age of the operator.
3. Never mow while people, especially children, or pets are nearby.
4. Keep in mind that the operator or user is responsible for accidents or hazards occurring to other people or their property.

Preparation

1. While mowing, always wear substantial footwear and long trousers. Do not operate the equipment when barefoot or wearing open sandals.
2. Thoroughly inspect the area where the equipment is to be used and remove all objects which can be thrown by the machine.
3. Warning - petrol is highly flammable.
 - Store fuel in containers specifically designed for this purpose.
 - Refuel outdoors only and do not smoke while refuelling.
 - Add fuel before starting the engine. Never remove the cap of the fuel tank or add petrol while the engine is running or when the engine is hot.
 - If petrol is spilled, do not attempt to start the engine but move the machine away from the area of spillage and avoid creating any source of ignition until petrol vapours have dissipated.
 - Replace all fuel tank and container caps securely.
4. Replace faulty silencers.
5. Before using, always visually inspect to see that the blades, blade bolts and cutter assembly are not worn or damaged. Replace worn or damaged blades and bolts in sets to preserve balance.
6. On multi-bladed machines, take care as rotating one blade can cause other blades to rotate.

Operation

1. Do not operate the engine in a confined space where dangerous carbon monoxide fumes can collect.
2. Mow only in daylight or in good artificial light.
3. Avoid operating the equipment in wet grass, where feasible.
4. Always be sure of your footing on slopes.
5. Walk, never run.
6. For wheeled rotary machines, mow across the face of slopes, never up and down.
7. Exercise extreme caution when changing direction on slopes.
8. Do not mow excessively steep slopes.
9. Use extreme caution when reversing or pulling the lawnmower towards you.
10. Stop the blade(s) if the lawnmower must be tilted for transportation when crossing

surfaces other than grass, and when transporting the lawnmower to and from the area to be mowed.

11. Never operate the lawnmower with defective guards, or without safety devices, for example deflectors and/or grass catchers, in place.
12. Do not change the engine governor settings or over speed the engine.
13. Disengage all blade and drive clutches before starting the engine.
14. Start the engine or switch on the motor carefully according to instructions and with feet well away from the blade(s).
15. Do not tilt the lawnmower when starting the engine or switching on the motor, except if the lawnmower must be tilted for starting. In this case, do not tilt it more than necessary and lift only the part which is away from the operator.
16. Do not start the engine when standing in front of the discharge chute.
17. Do not put hands or feet near or under rotating parts. Keep clear of the discharge opening at all times.
18. Never pick up or carry a lawnmower while the engine is running.
19. Stop the engine and disconnect the spark plug wire, make sure that all moving parts have come to a complete stop and, where a key is fitted remove the key:
 - Before clearing blockages or unclogging chute.
 - Before checking, cleaning or working on the lawnmower.
 - After striking a foreign object. Inspect the lawnmower for damage and make repairs before restarting and operating the lawnmower.
 - If lawnmower starts to vibrate abnormally (check immediately).
20. Stop the engine and disconnect the spark plug wire, make sure that all moving parts have come to a complete stop and, where a key is fitted remove the key:
 - Whenever you leave the lawnmower.
 - Before refuelling.
21. Reduce the throttle setting during engine shut down and, if the engine is provided with a shut-off valve, turn the fuel off at the conclusion of mowing.
22. Go slow when using a trailing seat.

Maintenance and storage

1. Keep all nuts, bolts and screws tight to be sure the equipment is in safe working condition.
2. Never store the equipment with petrol in the tank inside a building where fumes can reach an open flame or spark.
3. Allow the engine to cool before storing in any enclosure.
4. To reduce the fire hazard, keep the engine, silencer, battery compartment and petrol storage area free of grass, leaves, or excessive grease.
5. Check the grass catcher frequently for wear or deterioration.
6. Replace worn or damaged parts for safety.
7. If the fuel tank must be drained, this should be done outdoors.

ASSEMBLY

Assembling the handle

As shown in Fig 2&3

1. Fasten the lower handle to the device by using two bolts and two small knobs on each side.
2. Unfold the upper handle and fix it to lower handle by using the big knobs and the bolts on each side

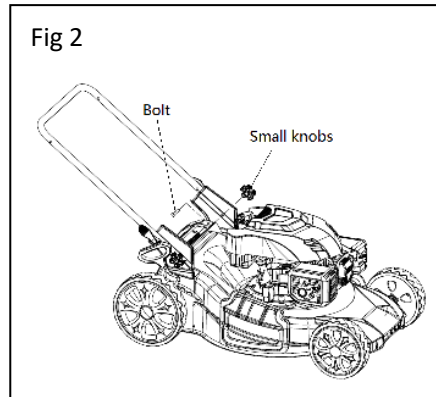

NOTE: Make sure the rope guide is on the right handle, when you stand behind the mower.

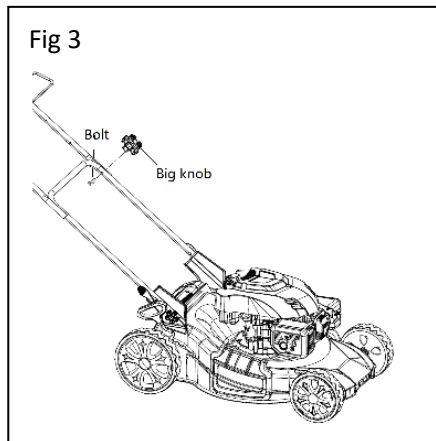

Tidy the connection cord

As shown in Fig 4

Fix the connection cord to the handle with the cord clip. (supplied)

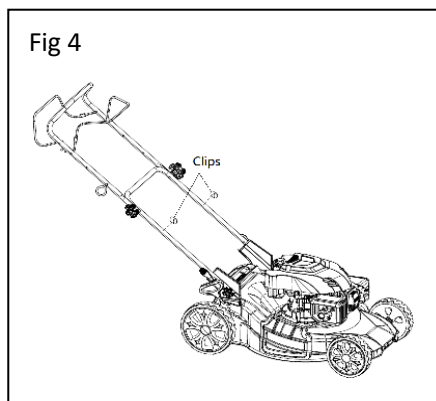

Assembling the grass bag

As shown in Fig 5

1. Clip the plastic clips over the metal frame. Make sure, that these clips are fully secured to the metal frame.

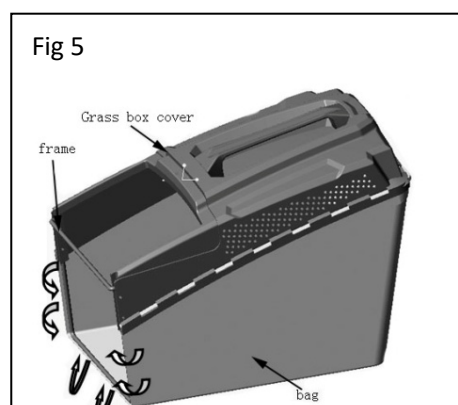

Assembling the grass bag onto the mower

As shown in Fig 6

1. Lift the rear discharge cover with one hand and hook in the grass bag.
2. Release the rear discharge cover to secure the grass bag in position

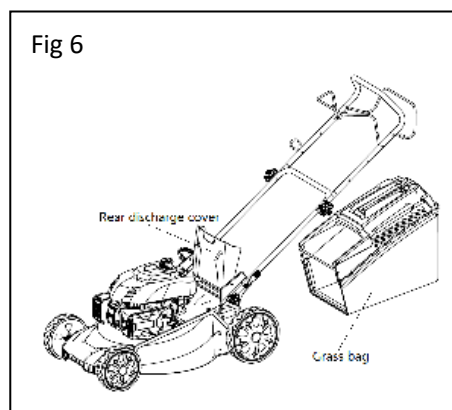

Assembling the mulching plug

As shown in Fig 7

1. Remove the grass bag
2. Push the plastic mulching plug into the discharge chute until it is locked in place.
3. Then release the flap, it will close back to cover the mulching plug.

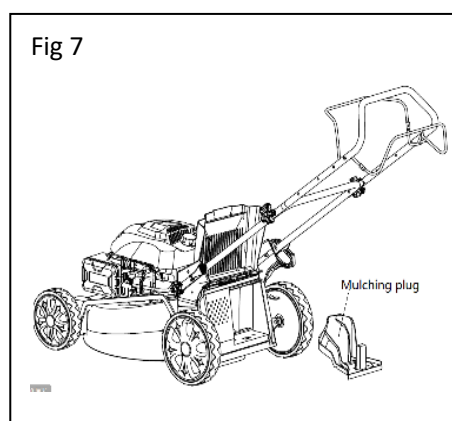

Assembling the side discharge chute

As shown in Fig 8



NOTE: When using the side discharge function, You first need remove the grass bag and plug in the mulching plug.

1. Lift the side discharge cover with one hand and hook in the side discharge duct with the other hand.
2. Release the side discharge cover to secure the duct in position

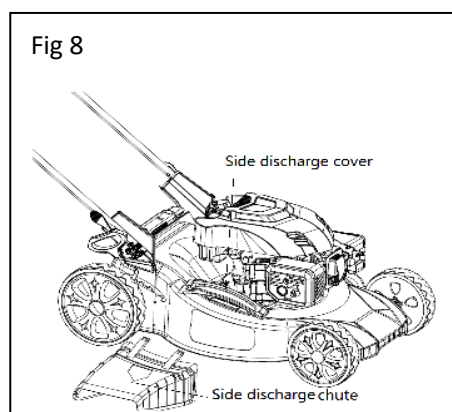



Checking the engine oil level And filling with engine oil

As shown in Fig 9 -11

 **CAUTION!** The following procedures and adjustments must be performed before the engine is started.
Do not attempt to make any of these adjustments while the engine is running.

 **CAUTION!** To prevent engine damage the engine is shipped without oil or petrol. The engine must be filled with the correct grade of oil and petrol before starting the engine.

 **NOTE!** Running the engine with a low oil level will cause engine damage. It is recommend that high detergent, premium quality 4-stroke engine oil used. Using non-detergent oil can shorten the engine's service life and using 2-stroke oil will damage the engine.

 **CAUTION!** Always use high quality detergent oil classified SAE30 oil (or equivalent e. g SAE 10W/30, often termed as 4 Stroke lawn mower oil). Never use additives with recommended oil. To prolong the life of your engine it is important that the oil is changed after the first 5 hours of use.

 **NOTE:** To Check the engine oil level, stop engine and place the mower on a level surface.

1. Remove the oil filler dipstick and wipe oil from it with a clean cloth.
2. Insert the dipstick into the oil filler neck, but do not turn it in.

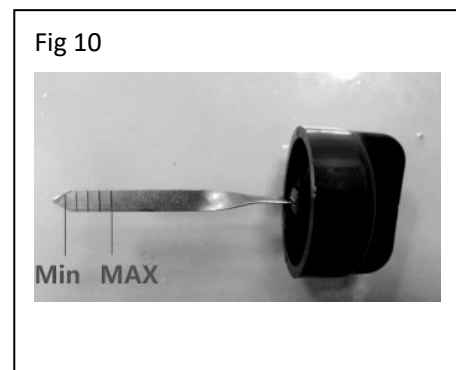
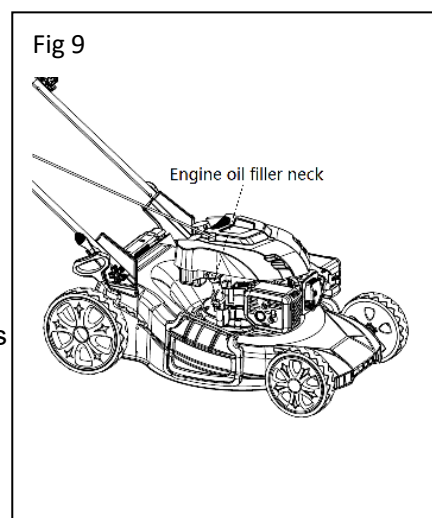

3. Then remove the dipstick and check the oil Level. the oil level must be between the Min and Max marks on the dipstick. If near the lower level, fill to upper lever with the recommended oil ((SAE30 or equivalent). Do not overfill. Wipe away any spilt oil.)
4. Align the ribs of the cap with the groove of the filler neck. then rotate 1/4 turn to secure it.

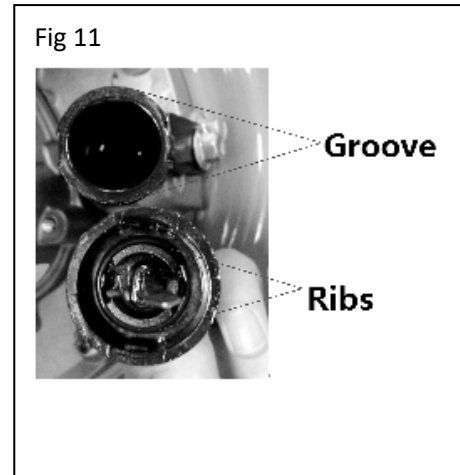

Filling with engine fuel

As shown in Fig 12



CAUTION! Always use clean, fresh unleaded petrol. Purchase fuel in quantities that can be used within 30 days. Never mix oil with petrol.



CAUTION! Do not fill into the base of neck to allow for fuel expansion. Do not overfill the fuel tank.



CAUTION! WARNING! Petrol is highly flammable and extreme precaution must be taken when handling or working with it. Keep out of reach of children.



CAUTION! To prevent engine damage the engine is shipped without oil or petrol. The engine must be filled with the correct grade of oil and petrol before starting the engine.



WARNING! Refuel in a well-ventilated area with the engine stopped. Do not smoke or allow flame or sparks in the area where the engine is refueled or where petrol is stored. Avoid repeated or prolonged contact with skin or inhalation of vapour

1. Clean the area around the petrol filler cap before removing the cap. Remove the warning tag, check the fuel level.
2. Refill the tank if the fuel level is low.
3. Refuel carefully to avoid overfilling or spilling fuel. There should be no fuel in the filler neck.
4. Clean up any overflow or splashes of petrol before starting the engine.
5. Tighten the filler cap after filling, finger tight on.

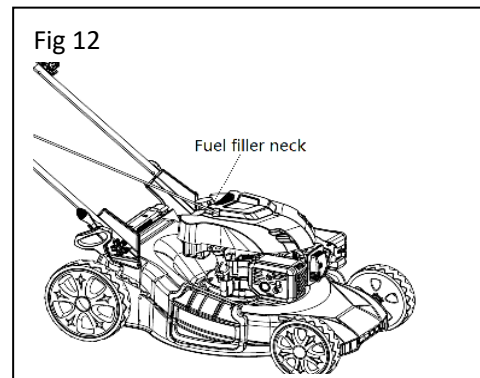

ADJUSTMENT

Setting the cutting height

As shown in Fig 13



CAUTION! Adjust the cutting height only

When the engine is switch off the spark plug
Boot has been pulled.

The cutting height is centrally adjusted with
Cutting height adjusting handle. Different cutting
Heights can be selected.

Pull the adjusting handle out and select the
Desired cutting height. The handle snaps
Into the desired position.

From position 1 to position 7. The cutting height
Range from 25mm to 75 mm

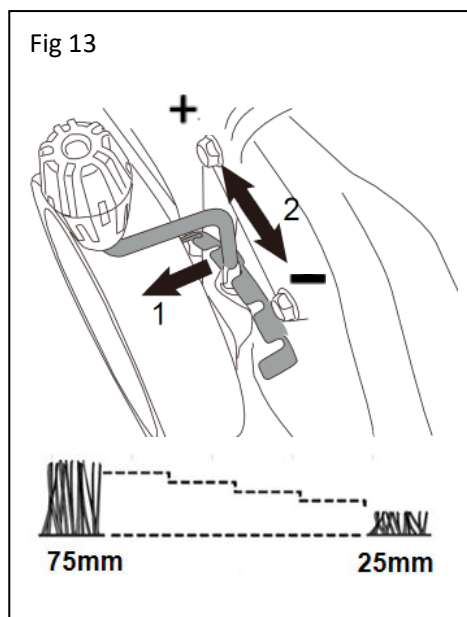

Setting required function



NOTE: This lawn mower has three functions. These functions can be converted by
changing accessory setting. Please see the following chart for detail setting.

To convert mower	mulching plug	Grass bag	side discharge duct
For rear discharging	×	×	×
For rear bagging	×	√	×
For mulching	√	×	×
For side discharging	√	×	√

“√”: installed “×” :removed

OPERATION

Start and stop the engine

 **WARNING:** the blade begins to rotate
As soon as the engine is started.

 **NOTE:** do not operate the machine in enclosed or poorly ventilated areas as the exhaust gas contains toxic substance. Keep hands, feet, hair and clothing away from all the moving parts of the machine. The exhaust and other parts of the machine will become hot during use. Make sure that the blade is securely fastened before starting the engine.

 **NOTE:** to start the engine, make sure that the spark plug boot is located on the plug and the machine is filled with sufficient oil and petrol.

To start the engine

As shown in Fig 14-15

1. When starting a cold engine, press down the Primer fully 3-5 times. (For lawnmower with BS engine Need to put the throttle control lever on the **START** position before starting )

 **WARNING!** Too much presses on primer may cause engine flooded. When starting a warm engine, the primer does not need to be used. If the engine stops due to a lack of petrol, refill and press down the primer 3~5 times.

2. Stand behind the mower. Pull the engine start/stop lever toward upper handle with one hand. Place the other hand on the starter handle.
3. Pull the starter handle out approx. 10-15cm

Fig 14

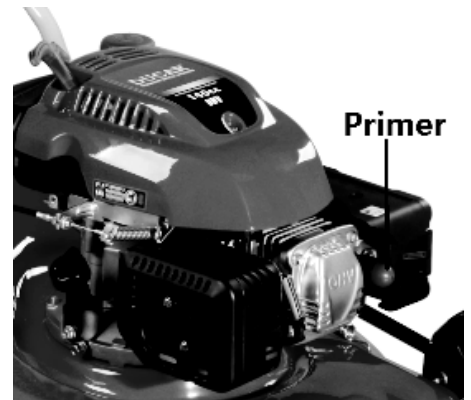

Fig 15



Until you feel a resistance and then start the Engine with a sharp pull.



NOTE: If the engine fails to start after three pulls, repeat the process.

4. Once the engine is running, put the starter rope into the rope guide. As shown in Fig 16

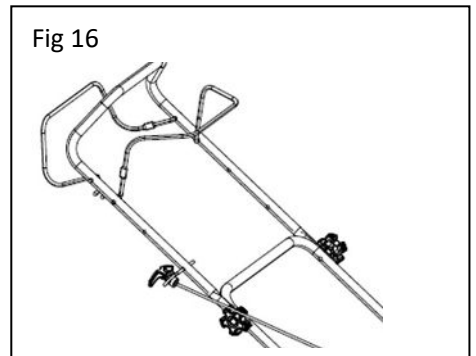

To stop the engine

As shown in Fig 17

Release the engine start/stop lever, it will return to its Initial position, the engine will automatically switch off.

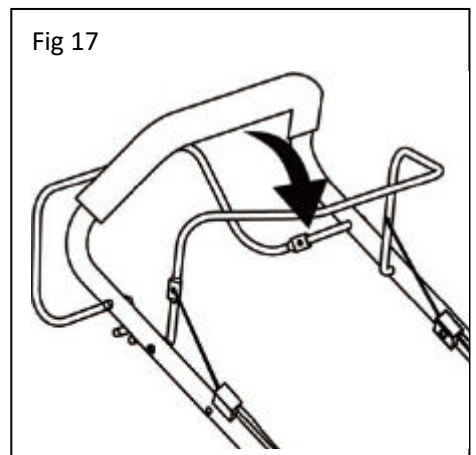

To clean a flooded engine



NOTE: if the engine won't start after you have Operated the starter several times , the engine may be flood with excess fuel . Use following procedure to clear and start a flooded engine.

1. Release the engine start/stop lever to stop engine.
2. Remove the spark plug, dry it, and then reinstall it.



NOTE: Install the spark plug carefully by hand, to avoid cross-threading. After the plug is seated tighten 1/8 to 1/4 turn with socket spanner of spark plug to compress the washer.

3. Pull the engine start/stop lever toward upper handle.
4. Operate the starter as described above.

Using the Self-propelled function

As shown in Fig 18

This unit equipped with self-propelled system. If you press the drive lever (clutch lever), the clutch for the drive will be closed and the lawnmower will start to move with the engine running. To stop the moving lawnmower, just simply release the drive lever in good time.

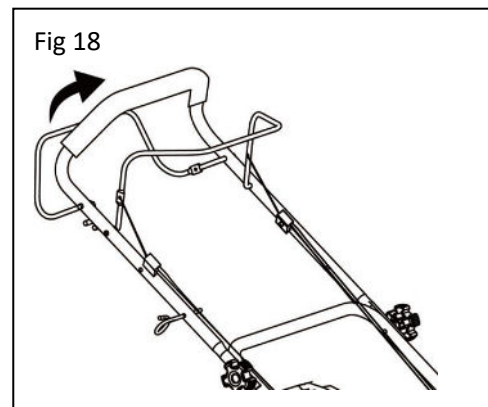

Mowing



WARNING: Always observe the strictest safety procedures when using the lawnmower. Carefully read the safety instructions of this manual before using the lawnmower.



WARNING: Never open the ejector flap when the grass bag has been detached (to be emptied) and the engine is still running. The rotating blade can cause serious injuries!

1. Select your required setting.
2. Start the engine and allow it run and set it to required speed.
See “to start the engine”.
3. Keep a firm grip on the upper handle with engine stop/start lever and drive lever (clutch lever) closed and walk along with it, self-propelling to start mowing.

Working advices

1. Walk, never run with the mower, be very careful when mowing uneven or rough ground.
2. Mow across slopes, never up and down.
3. Be careful when changing the direction of the mower on a slope.

4. Do not mow excessively steep slopes.
5. The best result will be achieved if the grass is dry. Wet grass will tend to clog the blade and the grass collection system.
6. Grass grows at different rates at different time of the year. Never use the lowest cutting height for the first cut of the season or in drought conditions.
7. Only about one thirds of the grass height should be cut.
8. When mowing with mulching, to ensure that the cut grass can be scattered efficiently, do not cut high or wet grass. When you have been cutting for several minutes, please stop the mower, and clean the blade and the deck.
9. Do not remove grass debris in the mower casing or on the blade by hand or with your feet. Instead use suitable tools such as a brush or broom.

Emptying the grass bag

As soon as grass clippings start to trail the lawn mower, it is time to empty the grass bag.



NOTE: Before taking off the grass bag, switch off the engine and wait until the blade has come to a stop.

1. To take off the grass bag, use one hand to lift ejector flap and the other to grab onto the carry handle. The ejector flap automatically falls after removing the grass bag and closes off the rear chute opening.
2. Empty the grass debris in the grass bag, and refit grass Bag.



NOTE: If any grass residue is caught in the discharge chute, clean it using a brush. Do not remove grass debris in the mower casing or on the blade by hand or with your feet. Instead use suitable tools such as a brush or broom. To ensure that the cut grass can be collected into grass Bag, the discharge opening and inside the mower casing must be cleared of any blockage.

STORING AND MAINTENANCE



WARNING: Before performing any maintenance or cleaning work, switch Off the engine and wait until the blade has come to a stop.

Cleaning

General cleaning

The lawn mower should be cleaned thoroughly every time after it has been used.

Always clean your lawnmower immediately after use.

Do not allow grass cuttings and other debris to become dry and hard on any of the mower

surfaces.

Dried grass remnants and dirt may impair the mowing operation.

Check that the grass chute is free of any residual grass. Remove any such residue. Check the underside of the lawn mower and the blade mount. for this purpose, tilt the Lawn mower onto its left side (opposite the oil filler neck)



NOTE: Before placing the lawn mower on its side, fully drain the fuel tank using a petrol extraction pump.

Do not tilt the lawn mower by more than 90 degrees.

Maintenance of the spark plug.

As shown in Fig 19

1. Once the engine has cooled, pull off the spark plug with a twist.
2. Remove the spark plug using a spark plug wrench
3. Clean the spark plug with a wire brush (not supplied).
4. Using a feeler gauge set the gap to 0.75mm
5. Install the spark plug carefully by hand, to avoid cross-threading.
6. After the spark plug is seated, tighten with the spanner to compress the washer.

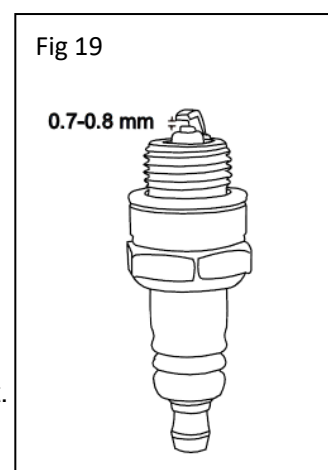

How to Service the Air Filter

As shown in Fig 20

Soiled air filters reduce the engine output by supply too little air to the carburettor. if the air contains a lot of dust, the air filter should be checked more frequently.



WARNING! Never run the engine without the air filter element installed.

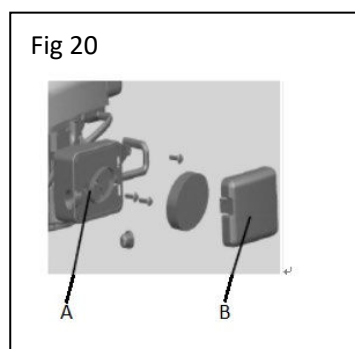

1. Remove the air cleaner outside cover (A).
Be careful to prevent dirt and debris from falling into the air cleaner assembly.

2. Separate the Air Filter (A) from the Air Filter Housing (B).
3. Inspect the air filter. Clean dirty air filter with warm water and mild soap. Allow air filter to dry thoroughly before re-installation
4. Install the air filter assembly onto the carburettor and secure with screw.

Note: Do not use pressurized air or solvents to clean the filter. Pressurized air can damage the filter and solvents will dissolve the filter.

Changing the engine oil

Tilt the lawnmower towards the oil filler, have a container ready to catch the oil and remove the dipstick. once the oil has been emptied, replace the dipstick and wipe clean any spillages.

Refill with 500ml SAE30 oil or equivalent i.e., SAE5W/30, SAE10W/30. When the dipstick is rested on the filler pipe (i.e., not turn in place), the oil level must be between the min and max marks on the dipstick.

See “Checking the engine oil level and filling with engine oil”

Start the engine and allow it to run briefly.

Stop the engine, wait one minute and check the oil level. top up if necessary.

Note! see more in engine manual.

Replacing the blade

For safety reasons you should only ever have your blade sharpened, balanced and mounted by an authorised service workshop. For optimum results it is recommended that the blade should be inspected once a year.



WARNING! Before you remove the grass collection bag, stop the engine and wait until the blade stops completely.



WARNING! You will need garden gloves (not provided) and a spanner wrench (not provided) to remove the blade.



NOTE! Don't invert the mower. Tip it slightly towards the oil filler pipe and reach under the deck



WARNING! Always handle the blade with care, sharp edges could cause injury **USE GLOVES**. Renew your metal blade after 50Hrs mowing or 2yrs whichever is sooner regardless of condition.



WARNING! If the blade is cracked or damaged replace it with a new one.



WARNING! Don't hold the blade by hand directly.



NOTE! Maintain the sharpness of the blade when cutting grass. If the blade has worn excessively and become pitted and blunt, it should be replaced or sharpened. The sharpness of the blade will affect the

performance of the lawnmower.

For safety reasons we recommend that the blade only be changed by someone qualified and authorized to do so.

Hold the blade and unscrew the blade bolt counter clockwise using a spanner wrench. Remove the washer and the blade.

Fit a new blade or re-sharpen the blade, locate the blade on the two studs on the blade flange and then replace the washer and bolts. Make sure the blade is correctly located, and then firmly tighten the bolt. Do not over tighten. The up turn of the blade must project into the motor compartment.

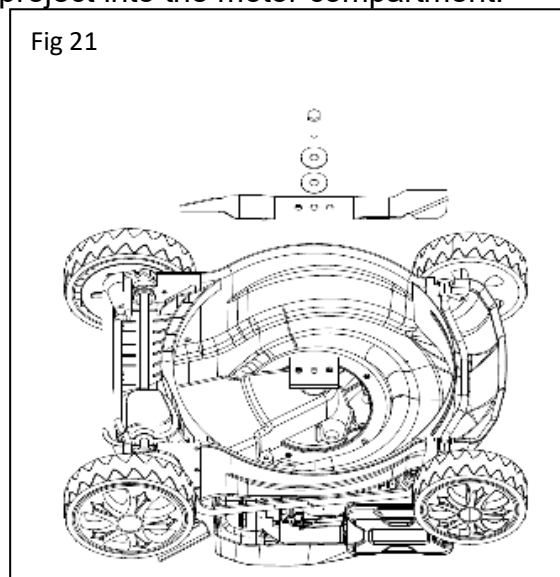

Storing the Lawnmower for Short Periods

The lawnmower can be stored for short periods of time (less than 15 days) without performing any storage maintenance. Before placing the lawnmower into storage always carry out the following:

1. Allow the engine to fully cool.
2. Ensure the grass bag is empty.
3. Clean all debris from under the mower deck.
4. Store the lawnmower on flat and level surface with the mower upright.
5. Store in a safe place which is not accessible by children or people who are not familiar with operation.

Storing the Lawnmower for Extended Periods

If the lawnmower is to be placed into storage for more than 15 days, storage maintenance must be performed on the lawnmower. If the following steps are not carried out, when you next operate the lawnmower, it may not start correctly and may need to be serviced.



CAUTION! Do not empty the petrol tank in enclosed areas, near fire or when smoking. Petrol fumes can cause explosions and fire

1. Empty the petrol tank with a petrol suction pump if available.
2. Start the engine and let it run until any remaining petrol has been used up.
3. Change the oil at the end of every season. To do so, remove the used engine oil from a warm engine and refill with fresh oil
4. Clean the cooling fins of the cylinder and the housing
5. Be sure to clean the entire machine to protect the paint.
6. Store the machine in a well-ventilated place.

Maintenance Schedule

Performing routine maintenance correctly on your lawnmower will ensure you get years of trouble-free use.

Please keep this manual safe for future reference.

It is recommended that the following maintenance schedule is adhered to. This will ensure the lawnmower operates correctly and is safe to use.

	12hours of use	24hours of use	36hours of use
Air filter	clean	Clean	replace
Spark plug	check	clean	replace
Engine oil	Check	Replace	check

The Engine oil should be changed after the first 8 hours.

Transport

Empty the petrol tank

Always let the engine run until it has used up the remainder of petrol in the tank.

Empty the engine oil from the warm engine.

Remove the spark plug boot from the spark plug.

Clean the cooling fins of the cylinder and the housing.

Use the original packaging to ship whenever possible.

TROUBLESHOOTING



WARNING: Before performing any maintenance or cleaning work, switch off the engine and wait until the blade has come to a stop.



Caution!

Improper repairs can result in the product functioning unsafely. This endangers yourself and your environment.

Faults which cannot be rectified with the aid of following table may be rectified by a specialist company only (customer service centre).

Please be aware that any improper repairs will also invalidate the warranty and additional costs may be incurred.

Use only genuine spare parts. Only these spare parts are designed and suitable for the product. The use of other spare parts not only voids the warranty, but you can also endanger yourself and your environment.

Fault/malfunction	Cause	Remedy
Loud while running, machine vibrates heavily	Screws are loose	Check screws
	Blade fasteners are loose	Check blade fasteners
	Blade is unbalanced	Replace blade
Engine does not start	Start/stop lever not pressed	Press start/stop lever
	Spark plug is defective	Replace spark plug
	Is the cutting blade worn or damaged?	Replace it by the customer service centre
	Fuel tank is empty	Refill with fuel
	Engine may be flooded	Remove plug and dry
Engine runs unsteadily	Air filter is soiled	Clean the air filter
	Spark plug is soiled	Clean the spark plug
Uneven mowing results	Blade is blunt	Sharpen the blade
	Cutting height is too low	Set correct height
Grass bag is not filled sufficiently	Blade is worn	Replace the blade
	Grass bag is clogged	Empty the grass bag
	Cutting height is right?	Correct the cutting height
	The lawn / grass is wet?	Allow the lawn to dry
	Is the discharge channel/ housing blocked?	Clean the discharge channel/ housing
	Is underside of the mower deck clogged?	Clean the underside of the mower deck